

PV-KK-SM and PV-KK-SMX

Blast Valves



The blast valve PV-KK-SM/-SMX is an application of the PV-KK blast valve for mounting on blast resistant wall surface or between ducts. It is specifically designed for installation in buildings where casting of the valve frame in concrete is not possible. The valve is also applicable to industrial applications with risk of chemical and dust explosions.

The PV-KK-SM/-SMX blast valve is available in single-column configurations of 1 to 6 valve blocks in a standard frame. Multi-column versions are described in a separate document. Contact Halton Marine for the availability of frames with special dimensions.

The number of blocks in valve depends on the air flow requirement at desired pressure drop. When the valve dimensions do not match the opening to be covered, custom made adaptors are available.

The PV-KK-SM/-SMX blast valve block comprises three spring balanced closing elements moving in a slot and closing the air passage against the valve seats in response to both positive and negative (suction) phase of the blast. The valve blocks are mounted in structural steel frames.

PV-KK-SM

The valve is completely corrosion resistant. The valve closing elements are made of special non-corroding aluminum alloy, all springs are made of stainless steel, and the valve body and frame made of structural steel are hot dip galvanized.

PV-KK-SMX

All the components of the valve are made of stainless steel. The version is especially designed for oil & gas, marine and navy applications.

Design criteria

The PV-KK-SM/-SMX blast valve is designed for a maximum long duration blast load with 100 kPa (1.0 bar) reflected peak pressure. The valve is tested with pressure waves having a finite rise time thus simulating hydrocarbon or dust explosions.

Test and performance data

The valve is verified by tests to effectively attenuate slowly rising (rise time = 10...100 ms) long duration (peak duration > 1000 ms) pressure wave loads within the load range up to 100 kPa (1.0 bar).

The valve is designed to function within the operating temperature range of -40...+200°C.

Test reports

Test reports no. RTE89/05 for PV-KK-SM and VTT-S-06-00231 for PV-KK-SMX by VTT Technical Research Centre of Finland are available upon request.

Installation alternatives

The valve is designed to be installed primarily onto the blast side of the blast resistant wall. The valve can be in upright or horizontal position or on ceiling/floor. The valve is installed on a concrete wall by means of anchor bolts of type HILTI HSA M12 x 100. The valve can be installed on a steel wall by welding or bolting using M12 machine bolts.

When welding the valve can also be mounted on the shielded side of the wall.

In duct applications the valve is bolted into duct flanges. The unshielded part of ducting must be blast resistant.

Product coding

The material and size of the single-column valves are indicated in the product code as follows:

- **PV-KK-SM-number** for hot dip galvanized steel
- **PV-KK-SMX-number** for stainless steel
where **number** = number of valve blocks

AIRFLOW CHARACTERISTICS

Airflow characteristics of one PV-KK-SM/-SMX blast valve block are given on the chart. The flow curve is measured at 20 °C corresponding to air density of 1.2 kg/m³. The required number of valve blocks in a specific application is determined by dividing the total air flow by the air flow capacity of one valve block at desired pressure drop.

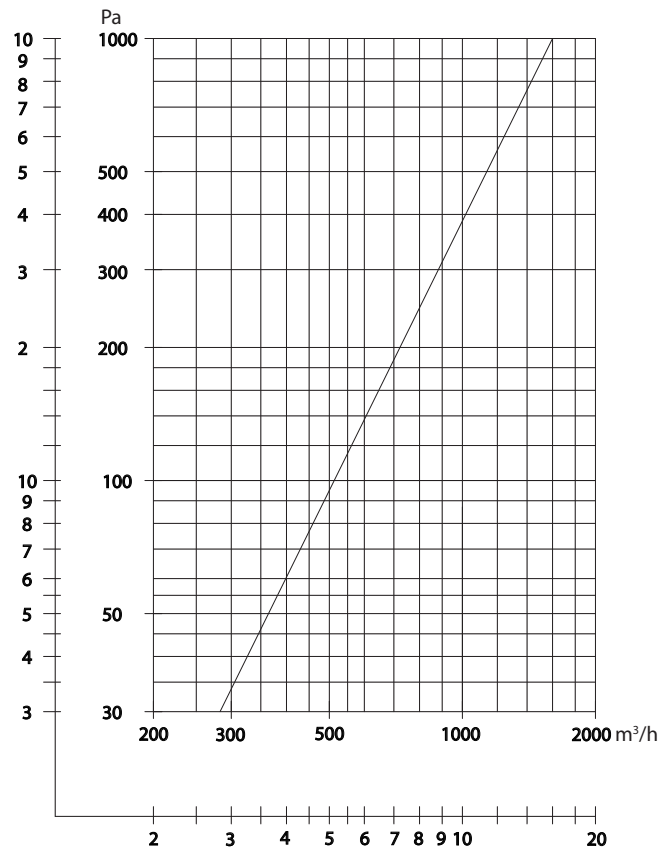

GENERAL PV-KK-SM/-SMX DRAWING, SINGLE-COLUMN

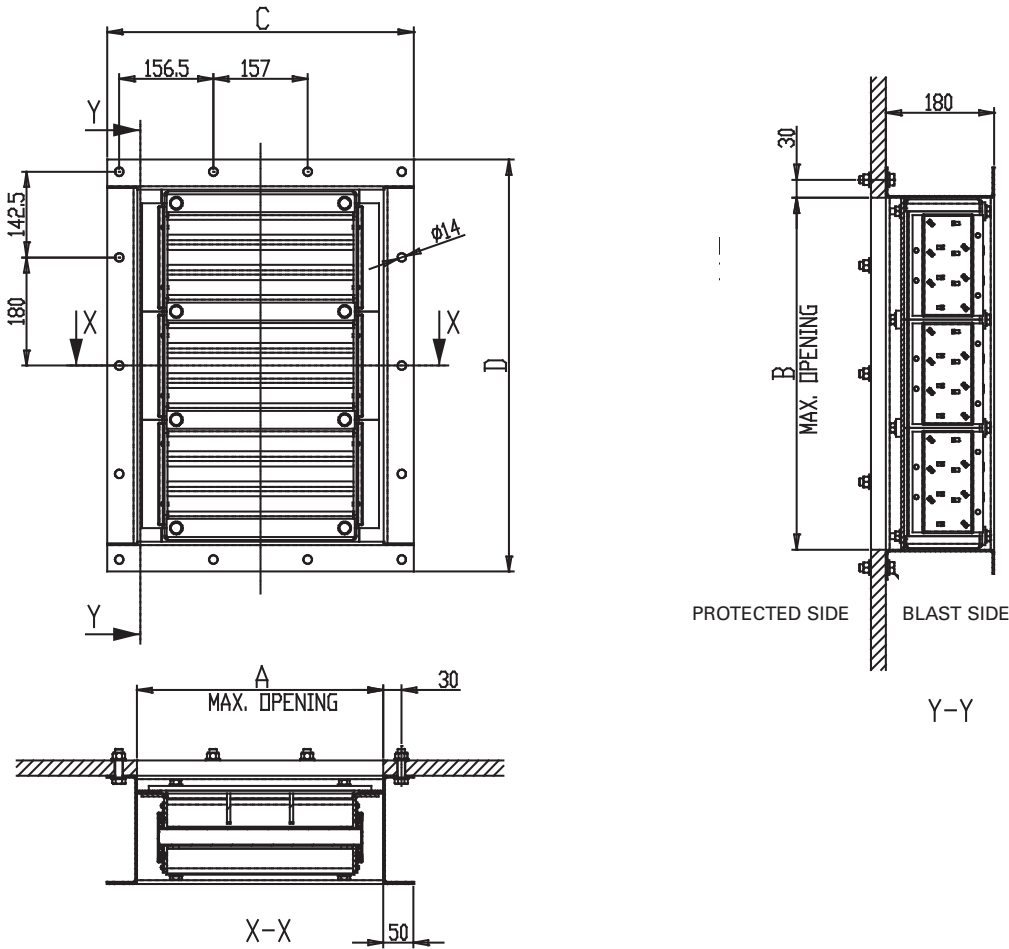

V4M05Y2010/Halton Marine reserves the right to alter products without notice.

Characteristics and dimensions of PV-KK-SM

| Valve type and code | Characteristics and dimensions | | | | | | | | | |
|---------------------|--------------------------------|------------------|------------------|------------------|--------|--------|---------------------------------------|---------------------------------------|---------------------------------------|-------------------|
| | Concrete wall (mm) | | Steel wall (mm) | | C (mm) | D (mm) | Airflow at 100 Pa (m ³ /h) | Airflow at 200 Pa (m ³ /h) | Airflow at 300 Pa (m ³ /h) | Total weight (kg) |
| | A _{max} | B _{max} | A _{max} | B _{max} | | | | | | |
| PV-KK-SM-1 | 260 | 125 | 410 | 225 | 510 | 325 | 500 | 720 | 900 | 20 |
| PV-KK-SM-2 | 260 | 255 | 410 | 405 | 510 | 505 | 1000 | 1440 | 1800 | 38 |
| PV-KK-SM-3 | 260 | 435 | 410 | 585 | 510 | 685 | 1500 | 2160 | 2700 | 55 |
| PV-KK-SM-4 | 260 | 615 | 410 | 765 | 510 | 865 | 2000 | 2880 | 3600 | 72 |
| PV-KK-SM-5 | 260 | 795 | 410 | 945 | 510 | 1045 | 2500 | 3600 | 4500 | 89 |
| PV-KK-SM-6 | 260 | 975 | 410 | 1125 | 510 | 1225 | 3000 | 4320 | 5400 | 106 |

Key characteristics of the valves are given above and relate to the drawings (steel wall installation as an example). The same figures apply to the PV-KK-SMX version. Note that the size of the opening to be covered depend on wall material due to safety margin in bolting.

